

A comparison of modelling wind turbine noise using FEA and BEM approaches

B. A. Marmo¹

1. Xi Engineering Consultants Ltd, Edinburgh, United Kingdom

Introduction

Broadband and tonal noise produced by wind turbines can have detrimental effects on neighboring residential communities. Xi Engineering Consultants have previously used COMSOL Multiphysics to design and optimize mitigation solutions targeted at the tonal component of wind turbine noise [1,2]. This previous modelling work employed finite element analysis (FEA) to model far-field noise. However, wind turbines by nature are formed by large almost linear objects with large regions of void space between the blades and tower and therefore require very large numerical meshes to model the sound field. However, the requirement of such large meshes limits the usefulness of FEA for wind turbine applications to small wind turbines (<30 m) and low frequencies (<100 Hz). To overcome the necessity of modelling the void spaces between blades, a novel approach was used whereby the acoustic fields around the blades and towers are modelled allowing the modelling of large turbines (up to 100 m) and higher frequencies (up to 200 Hz). While this approach was successful, it is still computationally expensive and the long modelling run times limited the number of tonal mitigation solutions that could be modelled.

The Boundary Element Method (BEM) that was recently introduced to the COMSOL Multiphysics acoustic module does not require a numerical mesh making it very well suited to wind turbine acoustic problems. This paper compares the modelling approaches using FEA and BEM and their relative model run times. A generic 1 MW wind turbine with 60 m tip height is modelled using fully coupled structural-acoustic models. The noise source modelled is taken to be tonal and related to gear meshing in the drive train.

Technical Background

Tones are very easily perceived by human hearing, so that tonal noise from wind turbines seems to increase the annoyance of receivers and has been identified as

the primary cause for complaint [3]. Consequently, legislation has been put into place to regulate tonal noise emitted from wind turbines, which, if not adhered to can lead to financial penalties, curtailment and even closure of a turbine site. The risk of such economic losses has influenced the wind turbine industry to develop solutions to tonal noise.

Tonal noise in wind turbines is commonly caused by the vibrations produced by the rotating components of the drivetrain. For example, vibration can be caused through the incorrect interlocking of gear teeth in the gearbox. This is commonly referred to as gear meshing. Normally, gearboxes have three step-up stages; a low speed stage with meshing in the 10 to 30 Hz range, an intermediate stage with 50 to 150 Hz meshing and a high-speed stage with 300 to 700 Hz meshing. These vibrations, while causing tonal noise, [4] may not necessarily be problematic, as the drivetrain is often a considerable distance away from the nearest receiver. However, if the frequency of vibration is closely aligned with structural resonant frequencies of the tower and/or blades, then the modal response can be excited. Therefore, amplifying and radiating tonal noise. Wind turbine towers are commonly lightly damped steel structures with very large surface areas, making them extremely efficient radiation surfaces for tonal noise.

Methodology

The wind turbine was modelled using a combination of shell and solid elements in the structural module. The structural model was coupled to acoustic domains and solved in the frequency domain with either a FEA or BEM approach. In previous work [1,2], the full drivetrain of the wind turbine was modelled. Here however, the focus is on the comparison of the FEA and BEM approaches, so the geometry and detail of the wind turbine was minimized such that the drivetrain was represented with a simple cylinder (Figure 1). The tower was modelled using shell elements with various thickness between 8 and 18 mm (Figure 2). The nacelle, hub and blades were modelled as solid elements. The densities of the solid elements were adjusted to give

representative mass of typical wind turbine components and the material parameters used in the model are listed in Table 1.

In the case of the FEA models the tower and each blade were surrounded by a cylinder of air modelled as an acoustic domain (Figure 3). To reduce the mesh size the tower was modelled with a half-cylinder. The external layers of these acoustic domains were modelled with perfectly matched layers to allow the acoustic waves to propagate out of the model space. Each of the acoustic domains had an individual far-field analyzer (Figure 4). The full integral was calculated for each far-field analyzer and a symmetry plane at $z = 0$ m used to represent acoustic reflections off of the ground. In the case of the BEM the turbine was surrounded by an infinite domain and a symmetry plane at $z = 0$ m used to represent acoustic reflections from the ground.

The acoustic domains in the FEA model were meshed using a boundary layers adjacent to the far-field analyzer surfaces. These layers were swept through the perfectly matched layer. The maximum mesh element size of the acoustic domain was maintained at less than one sixth of the wave length of the highest frequency sound wave modelled.

The shell and solid elements were coupled at the interface between the top of the tower and the base of the nacelle. The lower edges of the tower were fixed. The model was excited by applying forces typical of those measured on a 1 MW wind turbine associated with intermediate step-up stage gear meshing to the cylinder representing the drivetrain.

The models were solved on two computers with different specifications. The computers are referred to as Galileo and Joule. Galileo has a 6 Core 8th generation i5 Intel processor with 16 GB of RAM. Joule has a 16 core (32 thread) 1st generation Threadripper AMD processor with 128 GB of RAM.

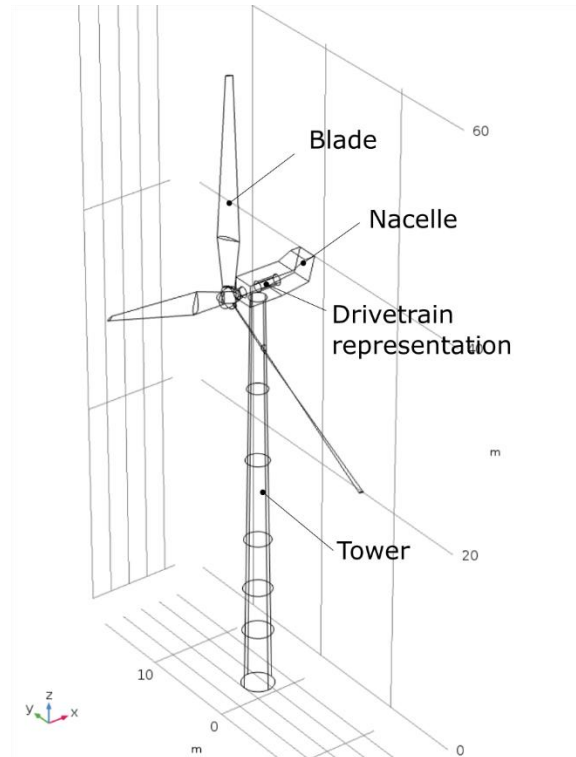

Figure 1. Structural component of the wind turbine with a cylinder representing the drivetrain

	Young's modulus	Poisson's Ratio	Total mass	Density	Speed of sound
	GPa		ton	kg/m ³	m/s
Tower	200	0.3		7850	
Blades	105	0.33	4	705	
Hub	200	0.3	8	1938	
Nacelle	200	0.3	45	1705	
Air				1.224	343

Table 1. Material properties used in the model

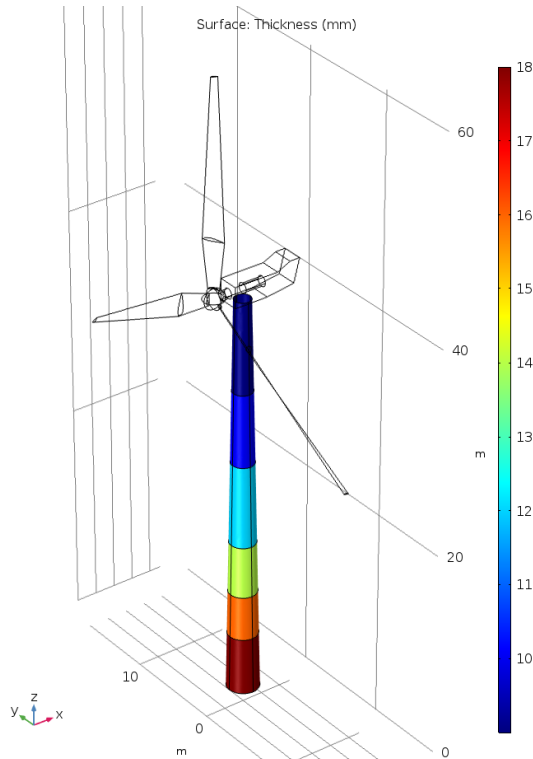

Figure 2. Steel tower modelled using shell elements with varying thickness

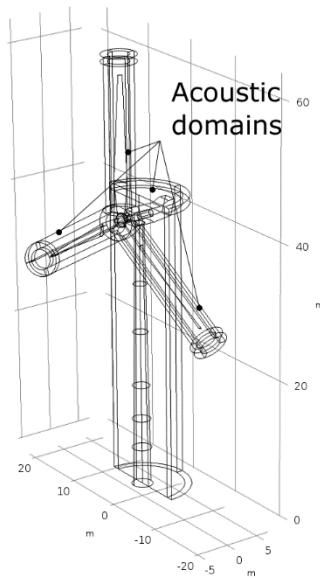

Figure 3. FEA model geometry. Each of the blades are surrounded by cylinders and the tower by a half cylinder that represent air in the acoustic domain. These acoustic domains each have external perfectly match layer.

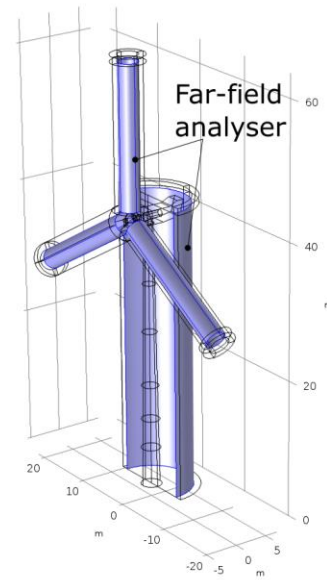

Figure 4. Boundaries used in individual far-field analyser for each blade and the tower

Results

The FEA and BEM models were solved in the frequency domain at $1/36^{\text{th}}$ octave intervals between 50 Hz and 150 Hz. The frequency response at 50 m down wind and 1 m above the ground were calculated for both models; in the case of the FEA model the complex pressure derived from the four far-field analyzers related to the three blades and tower were summed and the SPL derived (Figure 5). The sound pressure level and the topology of the frequency response calculated using the FEA and BEM are similar, with the exception of the presence of a peak at 78 Hz in the FEA model. The three-dimensional sound fields produced by the two models are also broadly similar (Figure 6), though the BEM model has higher localized levels close the turbine's blades.

The run times for each model are were compared for individual frequencies (Table 2). The models were run three times for each frequency shown in Table 2 and the run times averaged. In the case of the FEA model, the mesh size of the acoustic domain was varied with frequency such that the maximum mesh element was one six the wave length of sound in air for the given frequency, thus the number of mesh elements increased with frequency.

Run times of the FEA models increased exponentially with frequency; the solve time on

Galileo increased from 18 seconds at 50 Hz to 1420 seconds at 150 Hz. Galileo was not capable of solving the FEA model for frequencies greater than 150 Hz due to RAM limitations and Joule was not capable at frequencies greater than 200 Hz. Conversely, the BEM models solved in ~80 seconds for all frequencies between 50 and 150 Hz. The BEM model was also capable of solving all frequencies examine ranging up to 400 Hz, with slightly increased solve times (Table 2). For the scale of turbine modelled, the FEA solved quickest up to 90 Hz on Galileo and 75 Hz on Joule; at higher frequencies the BEM performed best with respect to time to solutions (Figure 7).

Frequency (Hz)	Number of mesh elements on FEA	Run time (s)			
		Galileo		Joule	
		FEA	BEM	FEA	BEM
50	101045	17.8	78.6	24.8	75.6
60	129853	25	81.8	33.6	81.9
75	198799	34.6	78.8	46.4	78.6
90	316765	58.6	79	79.6	78.6
100	402886	104.6	79.4	112.4	79.1
125	719133	609.6	81.4	236.2	79.9
150	1182243	1424.8	84.8	509.4	84.6
200	2593785		90.2	1892.2	93.6
300			102.8		102.4
400			108.6		113.6

Table 2. Comparison of time to solution using FEA and BEM on computers with different computation capacity Galileo (6 Core, 8th Gen. i5) and Joule (16 Core, 1st Gen Threadripper)

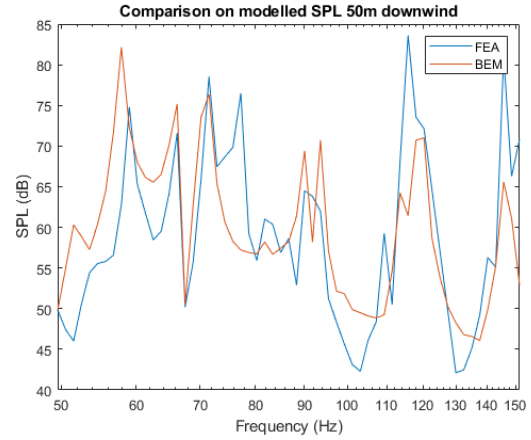

Figure 5. Comparison of sound pressure level modelled at a point 50 m downwind from the turbine 1 m above ground level

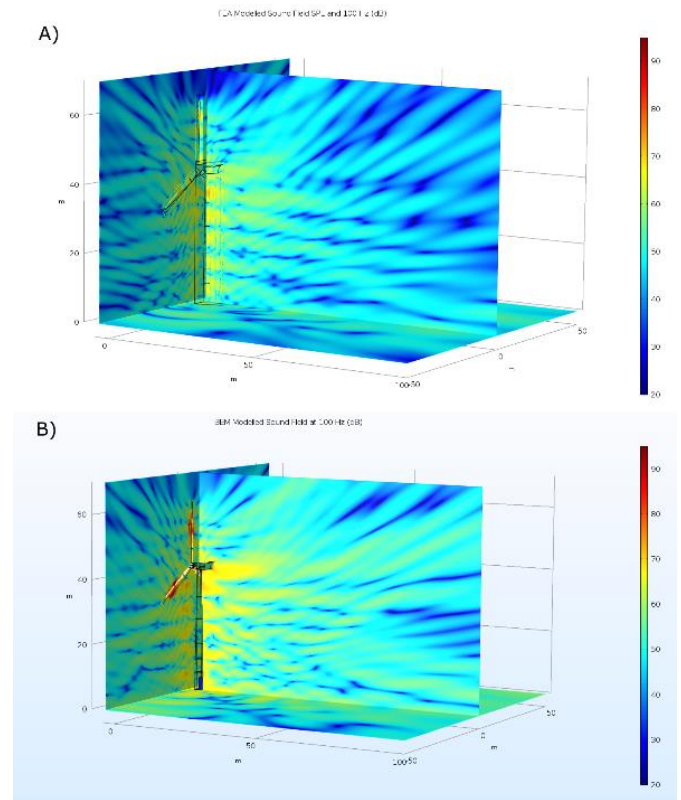

Figure 6. Comparison of sound fields produced at 100 Hz by the (A) FEA and (B) BEM models

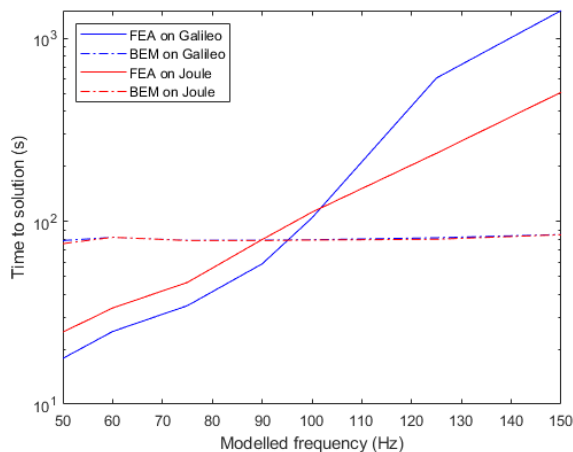

Figure 7. Comparison of time to solution for individual frequencies using FEA and BEM on computers with different computation capacity Galileo (6 Core, 8th Gen. i5) and Joule (16 Core, 1st Gen Threadripper)

Discussion

The FEA and BEM give similar results with respect to frequency response (Figure 5) and sound field distribution (Figure 6). Discrepancies in the frequency response between the two modelling approaches are likely due to spatial variations related to constructive and destructive interference in adding the far-field singles from the FEA.

The modelling work presented here used a medium sized wind turbine with a 60 m tip height and

demonstrated that as frequencies exceed ~75 Hz the boundary element method approach is more efficient at calculating far-field noise levels. Modern wind turbines are becoming increasingly large, with tip heights in excessive of 200 m in production. Modelling the three-dimension sound field using FEA for such large structures at frequencies in the human hearing range is not viable. The BEM approach used makes modelling large modern turbines numerically viable. The modelling here focused on the 50-150 Hz range which is a common problematic tone associated with intermediate stage gear meshing. Other problematic tones are associated with high speed meshing in the 300 to 700 Hz range which are not viable to model using the FEA approach due to the very fine mesh that would be required for the high frequency, short wave length sound waves. Modelling these higher frequency tones is viable using the BEM approach.

A further advantage of the BEM approach is the possibility of including geometric objects in far-field positions such as buildings and acoustic screens to model the sound field at the receptor locations (Figure 8). Such an approach makes it possible to optimize receptor-side noise mitigation solutions. Currently, receptor-size mitigation is modelled by considering the wind turbine as a points source; a BEM approach has considerable advantages as it models the full three-dimensionality wind turbine noise source. Furthermore, the relative numerical efficiency of BEM approach should make the modelling of sound level variation with rotor position practicable allowing modelling amplitude modulation of wind turbine noise.

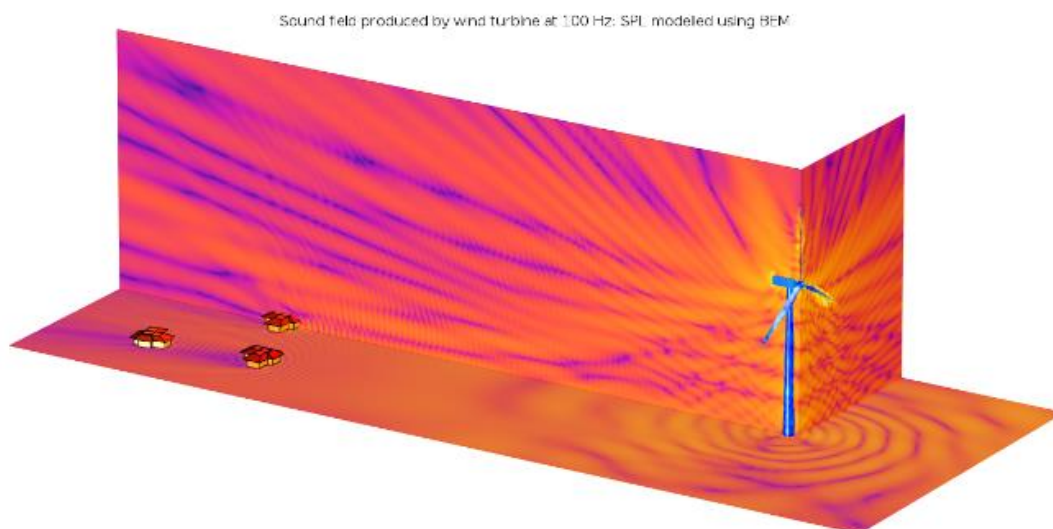

Figure 8. An example of using BEM to model the sound field emanating from a wind turbine and its interaction with down-field housing

Conclusions

The boundary element method used in COMSOL Multiphysics acoustic model is very well suited to modelling the acoustic output of wind turbines. The FEA approach performs well at low frequencies (< 100 Hz) and for medium sized wind turbines. However, as the frequency of interest increases the number of mesh elements required to accurately solve the FEA become unfeasibly large. The BEM approach is less numerical efficient at low frequency compared to the FEA, however the times to solution do not increase exponentially with frequency making the approach viable for modelling higher frequencies and larger structures. The significantly lower time to solution using the BEM approach makes the comparison of a large population of potential tonal noise mitigation solutions using numerical methods commercially attractive.

References

1. Stauber, J.M. and Marmo, B.A., Developing solutions to tonal noise from wind turbines using COMSOL Multiphysics, *COMSOL Multiphysics Conference, Munich 2016*.
2. Stauber, J.M., Marmo, B.A., and Black, D., *Tonal Noise Mitigation on Wind Turbines*, 24th International Congress on Sound and Vibration, 23-27 July 2017, London. 2017.
3. ETSU-R-97, *The assessment and rating of noise from wind farms, Final report of the Working Group on Noise from Wind Turbines*, ETSU-R-97, ETSU, Harwell, UK 1996.
4. Burton, T., Sharpe, D. and Jenkins, N. *Wind Energy Handbook*, John Wiley & Sons, Chichester, England 2001.